



ECO PHYSICS nCLD 822 SSdhr

APPLICATION EXAMPLES

- Burners and boilers
- Aviation
- Manufacturers of gas turbines
- Certification and calibration
- DeNOx Plants
- Petrol industry
- Research and development



The nCLD 822 SSdhr analyzer is the next generation in two-channel high precision nitrogen oxide measurement. Unique in speed and reliability, the nCLD 822 SSdhr is modular designed and capable of directly and simultaneously measuring NO_x in rough samples from two hot and moist sources without additional gas preconditioning unit. The new and intuitive graphical user interface also individually displays and connects to other instruments' data.

Measurement of:

- 2 x NO_x

Two Instead of One

The nCLD 822 SSdhr includes everything that is needed for simultaneously measuring NO_x in two different gas samples. Dual sample gas inlet combined with two steel converters allows the user to measure two gas sources simultaneously, enabling comparison of the samples. The integrated hot tubing allows the instrument to analyze hot and moist samples without external gas cooler required. The electro-mechanical bypass system balances out pressure variations occurring in the sample flow. The steel converters are especially developed for rough gas samples. Calibration and adjustment of the unit runs quick and automatically with all necessary data available anywhere and at any time.

User Friendliness

The new touch sensitive graphical user interface enables the user to individually adjust the instrument operation and data management according to his/ her needs and applications. The bright 7" monitor gives a clear overview and allows numerical and graphical display of values. Multiple digital in- and outputs guarantee a maximal connectivity for your remote operation, control and maintenance of the nCLD 822 SSdhr, ensuring unsurpassed precision and reliability.

Compact, Modular and Intelligent!

The nCLD 822 SSdhr is manufactured in a new compact and modular layout, in which each essential component of the chemiluminescence analyzer hosts its own CPU and interacts with other CPUs by BUS-communication. This assembly increases accessibility and serviceability by reducing wiring and piping. The measurement principle will conform to the standard method for NO_x-detection in stationary source emissions (EN 15267).

- Rapid system integration and rack mounting
- Compact and modular design
- Virtually maintenance free even in continuous operation
- Four freely selectable measuring ranges

Graphical user interface for individual analyzer operation and data management

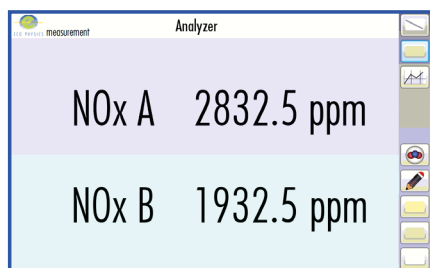

Measurably better

SPECIFICATIONS

nCLD 822 SSdhr

Analyzer type	dual chamber CLD with cooled PMT for measurement of two separate NO _x sources	Power required	350 VA (incl. membrane pump and ozone scrubber)
Measuring ranges	channel 1: two freely selectable ranges from 5 ppm - 5'000 ppm channel 2: two freely selectable ranges from 5 ppm - 5'000 ppm	Supply voltage	100 - 240 V/50 - 60 Hz
Min. detectable concentration*	channel 1: 0.12 ppm channel 2: 0.12 ppm	Interface	USB(3x), HDMI, Bluetooth, RS232 (w/o 9pin connector), LAN, WLAN
Noise at zero point (1σ)*	channel 1: 0.06 ppm channel 2: 0.06 ppm	Dimensions	height: 133 mm (5¼") width: 450 mm (19") with molding: 495 mm depth: 540 mm (21.2")
Lag time	<3 sec	Weight	23 kg (51 lb)
Rise time (0 - 90%)	<1 sec	Delivery includes	nCLD 822 SSdhr analyzer, power cable, FTDI-RS232-USB cable, USB-LAN adapter, HDMI adapter
Temperature range	5 - 40 °C	Standard	nCLD 822 SSdhr <ul style="list-style-type: none"> • SSd - dual channel with steel converters • h - hot tubing • r - electro-mechanical pressure regulation
Humidity tolerance	5 - 95% rel. h (non-condensing, ambient air and sample gas)	Options	<ul style="list-style-type: none"> • M - metal converters • USB-RS232 9pin connector • 0 - 10 V • 4 - 20 mA into 500 Ω max.
Sample flow rate	0.5 l/min per channel	Analog output (External Box)	
Input pressure	600 - 1'200 mbar abs.		
Dry air use for O₃ generator	internally generated (no external supply gas required)		

© ECO PHYSICS AG, Switzerland 2020 - 1 / 2

FLOW DIAGRAM

*Depending on filter setting
Connectivity properties are country-specific
ECO PHYSICS reserves the right to change these specifications without notice.

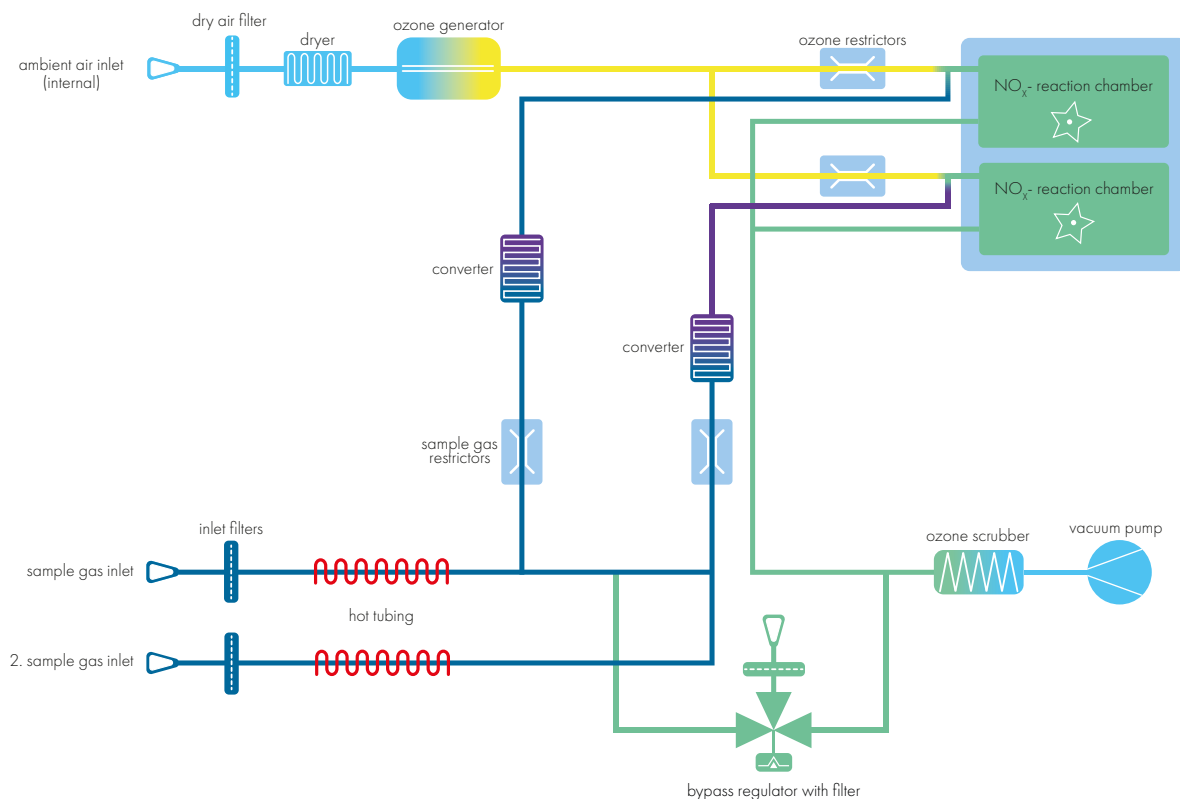

ECO PHYSICS

ECO PHYSICS AG · POB · CH-8635 DUERNTEN · TEL. +41 55 220 22 22 · E-MAIL INFO@ECOPHYSICS.COM

WWW.ECOPHYSICS.COM



Sintech Scientific (S.E.A.) Pte Ltd
 No. 194 Pandan Loop #04-11
 Pantech Business Hub
 Singapore 128383
 Tel : 65-67790007
 Fax : 63520877, 63520885
 Email : sales@sintechscientific.com
 Website : www.sintechscientific.com