



# ECO PHYSICS nCLD 855 Y

## APPLICATION EXAMPLES

- Gas manufacturers
- Manufacturers of gas turbines
- Certification and calibration
- DeNOx Plants
- Refining of fuels and lubricants
- Tobacco industry
- Research and development



*The nCLD 855 Y analyzer is the next generation in two-channel high precision nitrogen oxide measurement. Unique in speed and reliability, the nCLD 855 Y is modular designed and capable of simultaneously measuring NO, NO<sub>2</sub> and NO<sub>x</sub>. The analyzer's expandable capabilities allow assessment of hot and humid gas sources without additional cooler. The new and intuitive graphical user interface also individually displays and connects to other instruments' data.*

### Measurement of:

- NO
- NO<sub>2</sub>
- NO<sub>x</sub>

### nCLD - A New Generation

The nCLD 855 Y includes everything for measurement of NO, NO<sub>2</sub> and NO<sub>x</sub>. The fully revised detector-block, the enhanced gas flow paths and the improved pressure as well as temperature independence of the nCLD 800 Series instruments allow for even lower detection limits. Overall stability and reliability are lifted to a new level. The optional electro-mechanical bypass system balances out even fastest pressure variations occurring in the sample flow. Furthermore, the analyzer is adaptable to numerous non-standardized applications. The calibration of the unit runs quickly and automatically, with all necessary data available anywhere and at any time.

### User Friendliness

The new touch sensitive graphical user interface enables the user to individually adjust the instrument operation and data management according to his/ her needs and applications. The bright 7" monitor gives a clear overview and allows numerical and graphical display of values. Multiple digital in- and outputs guarantee a maximal connectivity for your remote operation, control and maintenance of the nCLD 855 Y, ensuring unsurpassed precision and reliability.

### Compact, Modular and Intelligent!

The nCLD 855 Y is manufactured in a new compact and modular layout, in which each essential component of the chemiluminescence analyzer hosts its own CPU and interacts with other CPUs by BUS-communication. This assembly increases accessibility and serviceability by reducing wiring and piping. The measurement principle will conform to the standard method for NO<sub>x</sub>-detection in ambient air (EN 14211).

- Rapid system integration and rack mounting
- Compact and modular design
- Virtually maintenance free even in continuous operation
- Four freely selectable measuring ranges

Graphical user interface for individual analyzer operation and data management

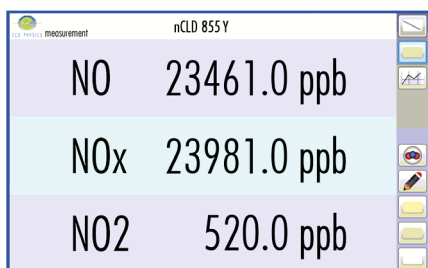

**Measurably better**

# SPECIFICATIONS

# nCLD 855 Y

Analyzer type	dual chamber CLD with cooled PMT for measurement of NO, NO <sub>2</sub> and NO <sub>x</sub>	Supply voltage	100 - 240 V / 50 - 60 Hz
Measuring ranges	four freely selectable ranges from 100 ppb - 50'000 ppb	Interface	USB(3x), HDMI, Bluetooth, RS232 (w/o 9pin connector), LAN, WLAN
Min. detectable concentration*	0.4 ppb	Dimensions	height: 133 mm (5¼") width: 450 mm (19") with molding: 495 mm depth: 540 mm (21.2")
Noise at zero point (1σ)*	<0.2 ppb	Weight	23 kg (51 lb)
Lag time	<3 sec	Delivery includes	nCLD 855 Y analyzer, power cable, FTDI-RS232-USB cable, USB-LAN adapter, HDMI adapter
Rise time (0 - 90%)	<1 sec	Standard	nCLD 855 Y · <b>Y</b> - molybdenum converter
Temperature range	5 - 40 °C	Options	· <b>V1</b> - single calibration valve · <b>V2</b> - two calibration valves for pressurized calibration (zero & span / 2-3 bar) · <b>h</b> - hot tubing · <b>r</b> - electro-mechanical pressure regulation · USB-RS232 9pin connector · 0 - 10 V · 4 - 20 mA into 500 Ω max.
Humidity tolerance	5 - 95% rel. h (non-condensing, ambient air and sample gas)	Analog output (External Box)	
Sample flow rate	1.0 l/min		
Input pressure	600 - 1'200 mbar abs.		
Dry air use for O <sub>3</sub> generator	internally generated (no external supply gas required)		
Power required	350 VA (incl. membrane pump and ozone scrubber)		

© ECO PHYSICS AG, Switzerland 2020-1/2

# FLOW DIAGRAM

\*Depending on filter setting  
Connectivity properties are country-specific  
ECO PHYSICS reserves the right to change these specifications without notice.

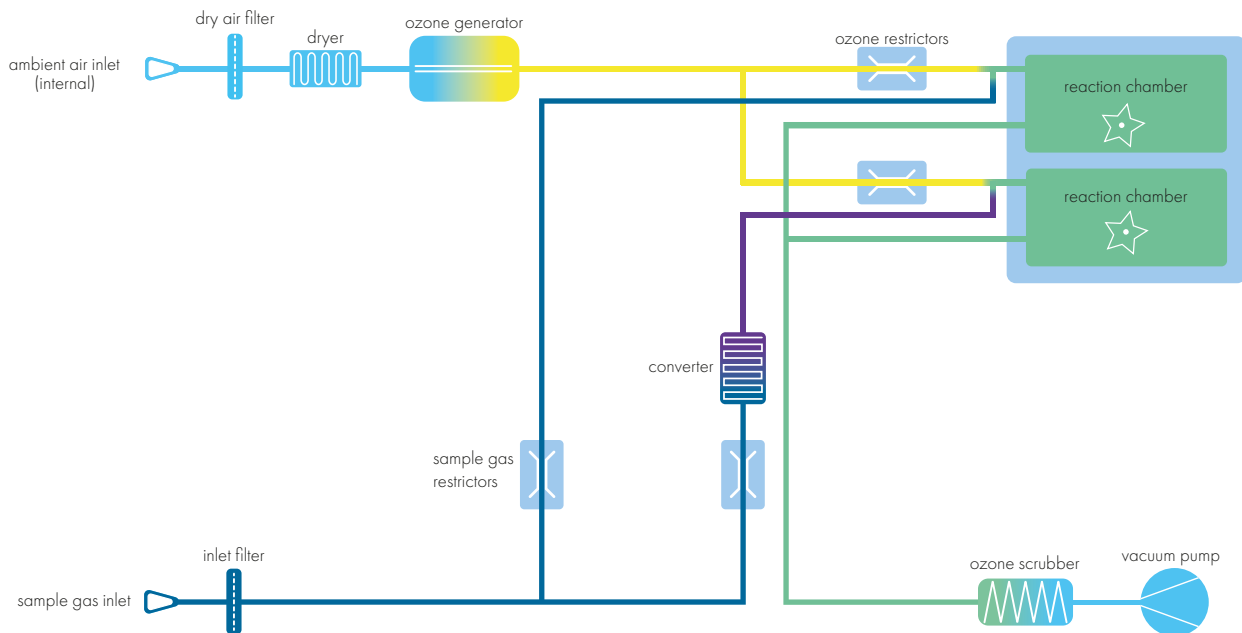

ECO PHYSICS

ECO PHYSICS AG · POB · CH-8635 DUERNTEN · TEL. +41 55 220 22 22 · E-MAIL INFO@ECOPHYSICS.COM

[WWW.ECOPHYSICS.COM](http://WWW.ECOPHYSICS.COM)



Sintech Scientific (S.E.A.) Pte Ltd  
No. 194 Pandan Loop #04-11  
Pantech Business Hub  
Singapore 128383  
Tel : 65-67790007  
Fax : 63520877, 63520885  
Email : [sales@sintechscientific.com](mailto:sales@sintechscientific.com)  
Website : [www.sintechscientific.com](http://www.sintechscientific.com)